

## **MICROBUBBLE AIR & DIRT SEPARATORS (Demountable)**

# **THE CLEANVENT (CVAD-R)**

The Air Free & Clean Solution

An air & dirt free water system through one unit

### **Deaeration**

The word Deaeration describes the removal of dissolved gases from liquids such as air from water. When water is heated or the pressure reduced gas microbubbles are released into the system. Microbubbles can be the cause of major problems such as pump failure, corrosion and energy loss.

### **The Solution**

The Cleanvent combines the removal of air and dirt through a single unit. Installed at the hottest point in the system the Cleanvent will eliminate these microbubbles from heating and chilled water systems.

### **Dirt Removal**

The Cleanvent is also used to remove dirt particles from heating and chilled water systems. Installed it will eliminate all dirt particles down to 10 microns.

### **Features**

- \* Greatly reduced commissioning times after initial fill.
- \* Longer system life (through air and dirt elimination)
- \* Low-pressure drop
- \* Bi-directional flow
- \* Max.temp. 110 c
- \* Max. Working pressure 10 bar
- \* Tested to 21 bar
- \* Standard carbon steel shell (stainless on request)
- \* Air collects in the air chamber before being automatically vented
- \* Floating dirt can be removed by opening the valve situated on the side of the unit.
- \* The same valve is used for releasing air when filling the system
- \* Large collector ensures that flushing is only required now and then
- \* Can be flushed while fully operational (no need to shut down)
- \* An internal stainless steel concentrator to aid removal of air and dirt.

### **Cleanvent Location**

This demountable combined unit (our model ref CVAD-R) must be installed at the hottest part of the system (before the pumps). In a heating system this is the main flow from the boilers. The static head must not exceed 30 metres.

In a chilled water system the unit must be located in the return close to the chiller. Maximum static head must not exceed 15 metres.

N.B. if the static head is greater than these figures the efficiency of the Cleanvent is reduced.

## **Dirt separation only**

This unit (our model ref CVD or CVD-R) should be installed in the return pipework before the flow of water enters any plant (boilers, pumps, etc.). There is no head restriction on this unit.

## **Air separation only**

This unit (our model ref CVA) must be installed at the hottest part of the system (before the pumps). In a heating system this is the main flow from the boilers. The static head must not exceed 30 metres.

In a chilled water system the unit must be located in the return close to the chiller. Maximum static head must not exceed 15 metres.

The maximum flow rates through the Cleanvent is 3m/sec. If these values are exceeded the efficiency is reduced.

## **Commissioning**

The Cleanvent requires no special commissioning. All units are fitted with a fast bleed valve, which should be used when initially filling the system. The same valve is used for draining off floating scum and also prevents the possibility of dirt clogging the air vent. Maintenance will be required to remove trapped dirt and sludge. Opening the ball valve at the bottom of the unit does this. The valve may be opened while the system is under pressure.

Scalding is a danger at high pressures and temperatures. Ensure that the water is safely piped to drain before opening the valve.

The system pressure will flush the dirt out. Leave the valve open until the collected dirt has been flushed out, repeat this operation every few days. Once the water is clear it may be possible to drain every 6 months or so depending on the size and age of the system.

Most of the dissolved air will be removed in a few days. However this may vary from system to system. In large systems it may take several weeks.

Dirt separators can only remove dirt that is circulating.

## **Flanges**

All flanges are drilled to BS 4504 PN16 as standard. Plain ends and other flange rating are available on request.

The Cleanvent unit is maintenance free.

## **Drain valve**

All models are supplied with a ball valve for draining the collected dirt and sludge.





## Positioning the “CLEANVENT” CVAD-R Combined microbubble air & dirt separator in the system is important for optimum performance.

In heating systems this should be in the flow, preferably at the highest temperature (next to the heat source) and low pressure if possible.

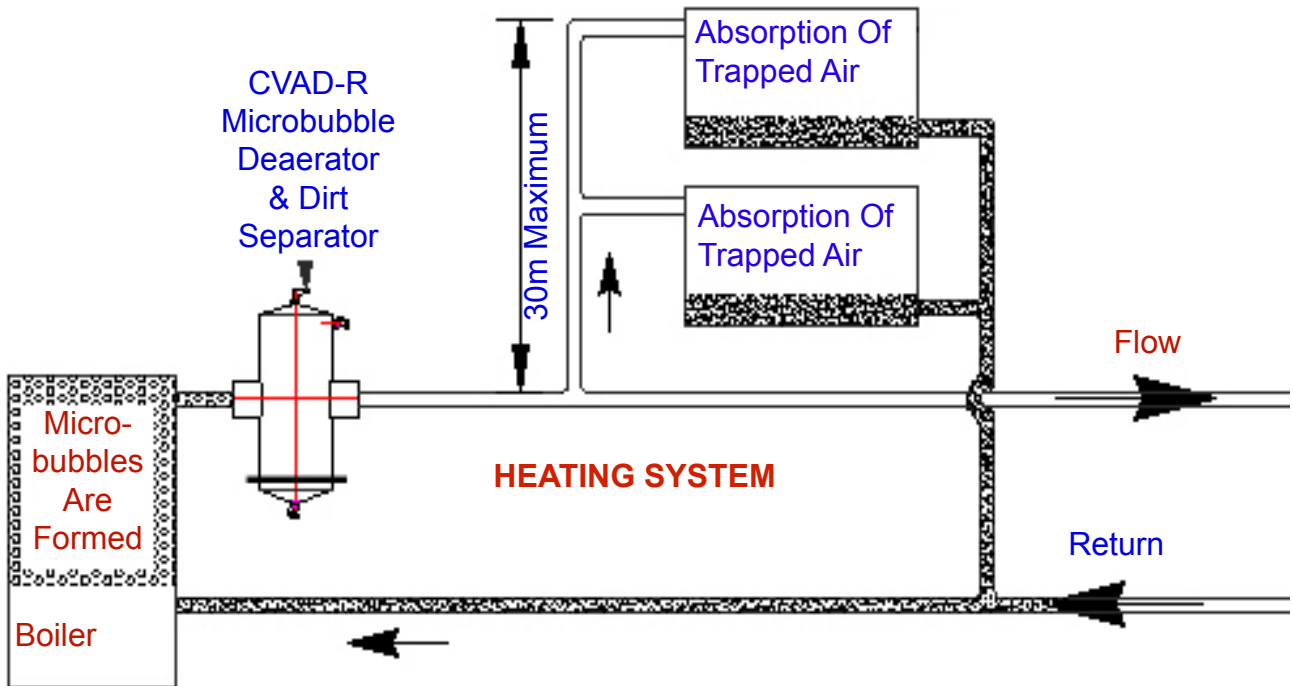

In cooling systems this should be in the return. The CVAD-R should always be installed before equipment that needs protection from dirt, sludge, etc., (ie. Chillers, control valves, pumps, etc.) In existing systems where there are problems with dirt, sludge, etc. a demountable unit should be installed, our CVAD-R will solve this problem. This applies to in and around the plantroom where new chiller unit and control equipment have been installed but the existing system has been left intact.

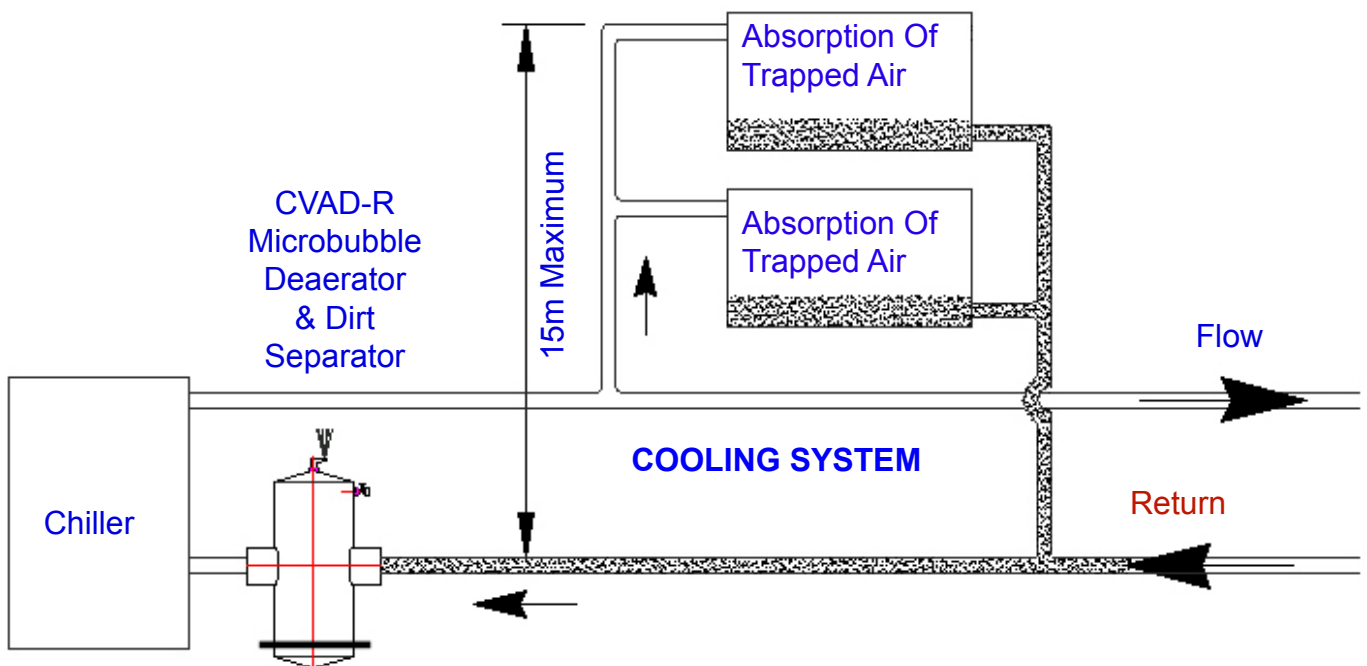

## Schematic instalation Schemes - "CLEANVENT" Range

This document describes where to install the "CLEANVENT" products in heating & cooling systems

### Specific rules

- 1) All models are in line units the water flows through them.
- 2) The positioning of the clean vent range to the pumps and control equipment is important !!
- 3) Consideration of all our range of units must be taken into account when specifying a unit applying to a specific contract.

- A) Is it a total new build.
- B) Is it a boiler house / plantroom refurbishment.
- C) Is there a particular problem with air or dirt (existing systems).
- D) Positioning of boiler house / plantroom regarding head of water.

### Air & Dirt or Air Only

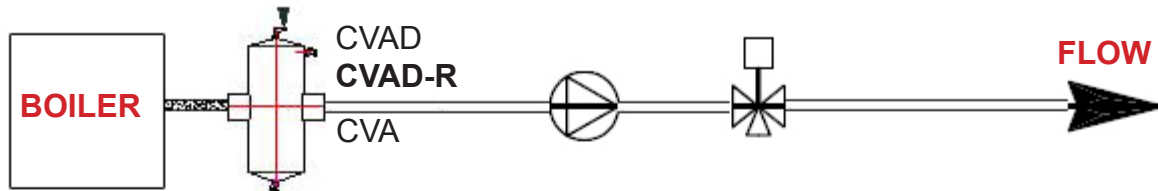

### Air & Dirt Only

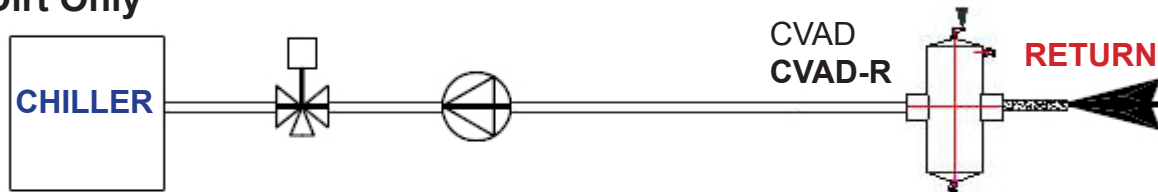

### Air & Dirt Only

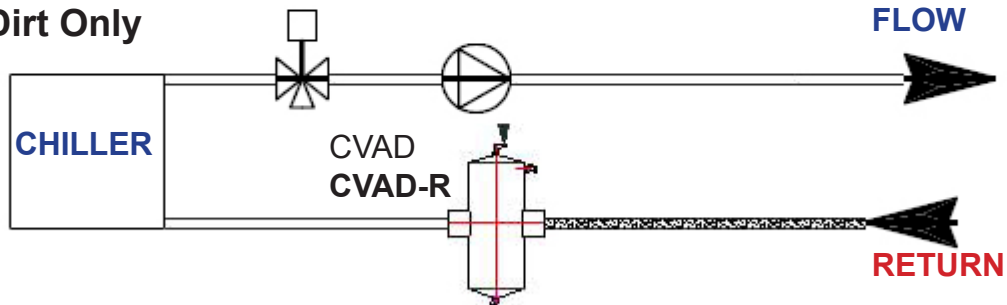

### Dirt Only

